

## K-600 Gas detector with Built in Pump ( Single or Multi )

K-600 portable multi-gas detector with built-in pump is a new intelligent gas detector, which adopts an advanced integrated circuit, with standard intelligent level design technology, and proprietary digital analog hybrid communication technology. The detector is of excellent sensitivity and repeatability, which makes it very easy to use and maintain. Thus greatly meets the safety requirements of industrial sites with high reliability. The detector is made of high-strength engineering plastics, compound non-slip rubber, which is of high strength and good hand feeling. what's more, the detector is water-proof, dust-proof and explosion-proof.

It is widely used in petroleum, chemical, environmental, metallurgy, refining, gas transmission and distribution, biochemical medicine, agricultural and other industries.



[Single or Multi]

# K-600 Gas Detector with Built in Pump

- Industrial sensor
- Four alarm methods
- Large capacity battery
- Chinese-English switching
- New UI
- Anti-fire, water,dust

### Sensors supported

Can detect more than 30 kinds of gases, can customize flexibly according to users' need (detect 5 different gases in one unit). normally detect Ex, O<sub>2</sub>,H<sub>2</sub>S,CO gases.

### Range

EX: 0~100%LEL  
O<sub>2</sub>: 0~30%VOL  
H<sub>2</sub>S: 0~100PPM  
CO: 0~1000PPM  
PH<sub>3</sub>: 0~100PPM

### Resolution

EX: 1%LEL  
O<sub>2</sub>: 0.1%VOL  
H<sub>2</sub>S: 1PPM  
CO: 1PPM  
PH<sub>3</sub>: 1PPM



### Technical Parameters

Gas sampling method:	Pumping
Alarm methods:	sound, light, vibration, curve display
Working Temperature:	-20°C-50°C
Power:	3.7V 360mA rechargeable lithium battery
Charging time:	4-6 hours
Display:	2.4 inch colored LCD display
Operating time:	working continuously for at least 10 hours
Explosion proof:	Exib IIC T4 Gb

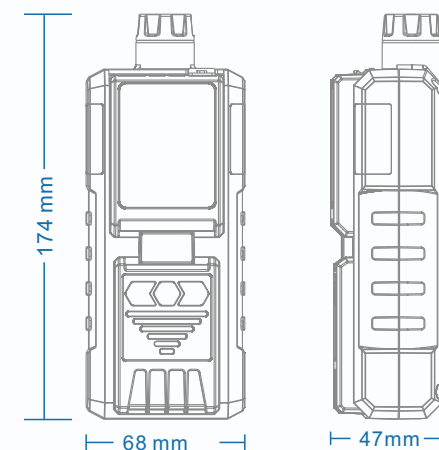

Size: 174x68x47mm