

Compound Gas Monitor Instruction Manual

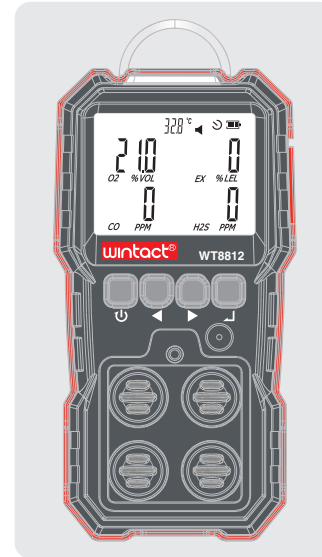

Contents

1.Before use

- Check up----- (01)
- Introduction----- (02)
- LCD Displays----- (03)
- Name of parts----- (04)
- Functions----- (05)
- Specifications----- (06)

2.Operation manual

- Main interface----- (07)
- Measurement Interface ----- (12)
- Record Checking Interface----- (13)

3.Others

- Charging function description----- (13)
- Warnings and Precautions----- (14)

1. Before use

Check up

Thanks for your purchasing our product, please check the following components after you unpacking the box. If there is any missing or wrong page manual, please contact the local dealer.

- Compound Gas Monitor (Contain Alligator clips) 1PCS
- Manual 1PCS
- Charger 1PCS
- Data line 1PCS
- Transparent trachea 1PCS
- Cover (with screws) 1PCS
- Packing box 1PCS

When you are ready to use this product, please make sure to read this manual first, and follow the relevant operations in usage so that you can fully understand the company's products and services while also avoiding unnecessary man-made damage or other accidents.

Introduction

Compound Gas Monitor adopts high-quality gas sensors, which displays safety and reliability with accurate measurement and stable performance. It has excellent sensitivity and repeatability, easy to use and maintain, and meets the requirements by safety monitoring in industrial site for high reliability of the equipment. The shell is made of high-strength engineering plastics and compound non-slip rubber, dust and explosion-proof, with high strength and smooth handfeel.

Compound Gas Monitor is widely used in petroleum, chemical, environmental protection, metallurgy, refining, gas transmission and distribution, biochemical medicine, agricultural research, etc.

This instrument conforms with the following procedures and calibration standards:

Gb3836.1—2010 Explosive Atmospheres Part 1: General Requirements for Equipment.

GB3836.4—2010 Explosive Atmospheres Part 4: Equipment with Intrinsically Safe "I" Protection.

GB15322.3—2003 Portable Combustible Gas Detectors Part 3: Portable Combustible Gas Detectors with a Measurement Range of (0~100) %LEL.

JJG693—2011 Verification Standards for Combustible Gas Detection Alarm.

JJG 365 — 2008 Verification Procedures for Electrochemical Oxygen Tester

JJG695-2003 Verification Procedure for Hydrogen Sulfide Gas Detector

JJG915-2008 Verification Procedures for Carbon Monoxide Detection Alarm

LCD Displays

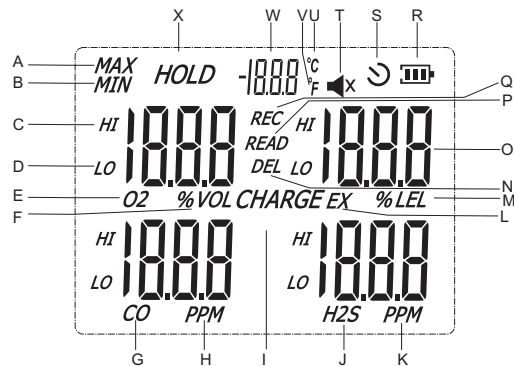



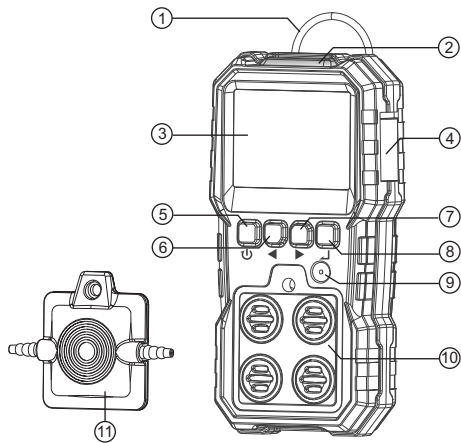

- | | |
|-----------------------|-----------------------------------|
| A. Maximum value | M. Unit of flammable gas |
| B. Minimum value | N. Delete |
| C. High alarm icon | O. Reading of flammable gas |
| D. Low alarm icon | P. Retrieval |
| E. Oxygen icon | Q. Record |
| F. Oxygen unit | R. Battery level reminder symbol |
| G. CO icon | S. Icon of turn-off |
| H. CO unit | T. Icon for buzzer turning on/off |
| I. Charge icon | U. Celsius unit |
| J. H2S icon | V. Fahrenheit unit |
| K. H2S unit | W. Temperature reading |
| L. Flammable gas icon | X. Reading hold |

Name of parts



(Figure 1)

1. Alligator clips on the back. 2. Transparent window for alarm indicator.
3. LCD display. 4. DC adaptor socket.
5.  On/off button: long press on the on/off button to turn the product on/off, short press on the button to activate or deactivate the backlight.
6.  Left button: Maximum/minimum mode lock
7.  Right button: Hold indicates is for hold the reading.
8.  Confirm button: long press on the Set button to enter into or exit set mode. Short press on REC to record data.
9. Buzzer alarm hole. 10. Gas sensing hole.
11. Gas calibration cover.

Functions

- Gas measurement: the sensor preheats while the turning-on countdown. The refresh frequency is 1HZ. Do not charge in the process of measuring the flammable gas or explosion may occur.
- High/low alarm: 4 default values for high/low alarm with 4 forms of alarm and the alarm voice can be turned off.
- Data record: up to 1000 pieces of data recorded allowable. The default interval of data record is 5 seconds which can be set in the inL in the set mode. When the interval is set as 0 second the data record function fails. Delete operation will delete all the data recorded.
- Temperature display: to set the unit as °C or °F, default unit is °C
- Automatic turning off: the unit turns off within 30 minutes if there is no further operation. Default turning on is this function.
- Battery volume: if the volume is the last bar or less it is highly recommended to charge the unit. It is forbidden to activate the unit to operate lest the possible measure error or explosion. If the battery is low it may turn off automatically. Charging time: about 4 hours. Discharging time: about 8 hours.
- Calibration of 0 point: it is recommended that the unit should be calibrated at the 0 point every month or if there is zero shift occurring to ensure the high accuracy of the measurement (please be sure that the battery volume is above 2 bars while calibration, and put the unit in the air for a while after turning on to ensure that the unit has its body temperature a little bit higher than the environmental temperature.
- Temperature compensation: the data measured is compensated at the range of -20°C to 50°C
- MAX/MIN/hold reading: press the button to calculate.
- Software error: the unit's crash/turn-off indicates the mistake occurs in process of operation. Press the on/off button to activate the unit if it is forced shutdown by software.

Specifications

Compound Gas Monitor range			
Measuring item	Unit	Range	Resolution
Combustible gas LEL	%LEL	0~100	0.1
Oxygen O ₂	%VOL	0~30	0.1
Hydrogen sulfide H ₂ S	PPM	0~100	0.1
Carbon monoxide CO	PPM	0~1000	1

*1PPM=1μmol/mol

Accuracy	≤±5%FS
Response time (90%)	Less than 30 seconds
Indication mode	LCD displays real-time data and system state, LED, sound, vibration indication alarm
Storage Conditions	Temperature:-10~55°C; Humidity:<85%RH
Operation Conditions	Temperature:-20~50°C; Humidity:<95%RH non-condensing
Working voltage	DC 3.7V (Lithium battery capacity 1800mAh)
Charging time	4h
Standby time	More than 8h on end (slightly change with working state)
Dimensions	71*153*49mm
Weight	218.7g With battery

2. Operation manual

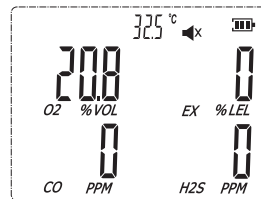

Main interface

1. Long press on/off button (back button) for about 2 seconds. After powering on, the instrument enters into the countdown interface (for the sensor takes about 8 seconds to stabilize). After the countdown is over, the main menu screen will appear, as shown in the right figure.



Main Menu Interface Display

2. Key Function:

- 1) On/off button : long press on the on/off button to turn the product on/off, short press on the button to activate or deactivate the backlight.
- 2) Left button : Under normal mode short press the MAX/MIN button to shift between the maximum and minimum values as shown in Figure 2 and long press to delete as shown in Figure 3.

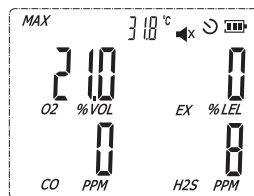

Figure 2

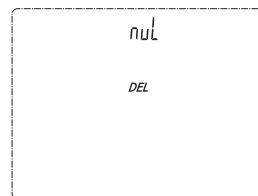



Figure 3

3) Right button : Short press the data hold button as shown in Figure 4 and long press it for reviewing the historical data as shown in Figure 5.

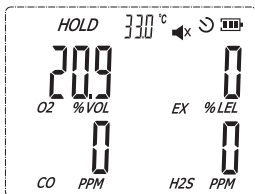

Figure 4

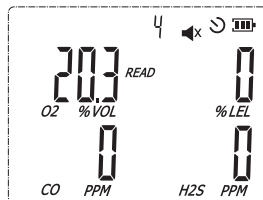



Figure 5

4) Confirm button : Press once the record character flashes and beeps to record the data as shown in Figure 6, press again to exit record mode.

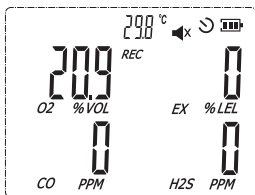

Figure 6



Figure 7

Long press this mode to enter into set mode with display ELE: under this mode press the left/right button to shift between the temperature unit °C and °F as shown in Figure 7.

Short press to switch to "OFF": automatic shutdown switch, press the left and right keys to display and hide the automatic shutdown symbol . as shown in Figure 8.



Figure 8

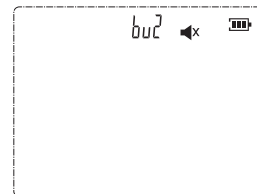

Figure 9

Bu2: under this mode press left/right key to turn on/off the alarm sound as shown in Figure 9.

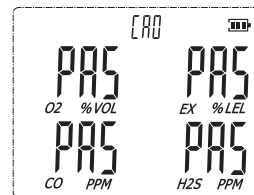

Figure 10

Ca0: under this mode, long press the right key to calibrate zero point and complete this process until it beeps for several seconds as shown in Figure 10.

ALA + Oxygen(high/low) : under this mode, press the left/right button to switch the high/low oxygen alarm value, long press on the right button to set the alarm value and adjust the value by press the left or right button, then press the confirm button to enter into next setting value. After all setting values are set, long press on the right button to complete the setting as shown in Figure 11.

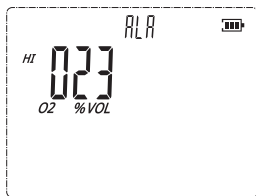

Figure 11

ALA + flammable gas(high/low): under this mode, press on the left/right button to switch the high/low flammable alarm value, long press on the right button to set the alarm value and adjust the value by press the left or right button, then press the confirm button to enter into next setting value. After all setting values are set, long press on the right button to complete the setting as shown in Figure 12.

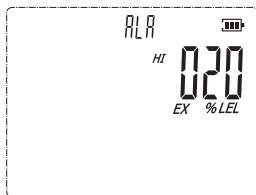

Figure 12

ALA + CO(high/low): under this mode, press on the left/right button to switch the high/low CO alarm value, long press on the right button to set the alarm value and adjust the value by press the left or right button, then press the confirm button to enter into next setting value. After all setting values are set, long press on the right button to complete the setting as shown in Figure 13.

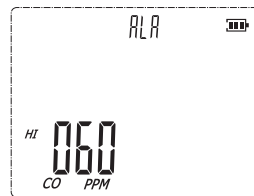

Figure 13

ALA + H2S (high/low): under this mode, press on the left/right button to switch the high/low H2S alarm value, long press on the right button to set the alarm value and adjust the value by press the left or right button, then press the confirm button to enter into next setting value. After all setting values are set, long press on the right button to complete the setting as shown in Figure 14.

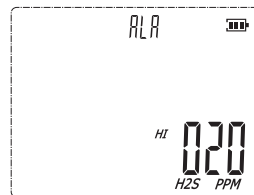

Figure 14

1nl: under this mode, long press on the right button to set the record interval, adjust the value by press the left or right button, then press the confirm button to enter into next setting value. After all setting values are set, long press on the right button to complete the setting. Long press on the left button is to write in the default ex-factory setting of high/low alarm values and record interval as shown in Figure 15.

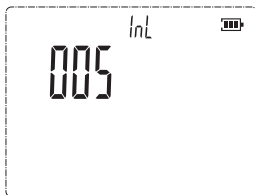
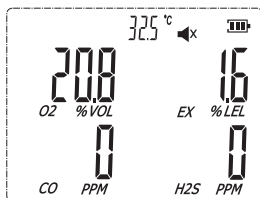

Figure 15

Measurement Interface

1. In this interface, there are 4 real time values of 4 items when the value is beyond the setting the value flashes and alarms if the alarm mode is activated.
2. If the gas concentration is lower than the low limit set, the instrument is of low alarm state if it is higher than the high limit set, the instrument is of high alarm state.



Measurement interface display

3. If alarm activated, it alarms with beeps and reading flashes as well as the indicator.
4. There are 4 forms of alarm as LED indicator flashing, reading flashing, sound beeps and vibration. The sound can be activated or deactivated in the set mode.

Record Checking Interface

Long press on the right button is to review the historical data recorded and press on the left button is to review every piece of data one by one. Long press on the left button to delete all data recorded as shown in the figure below.

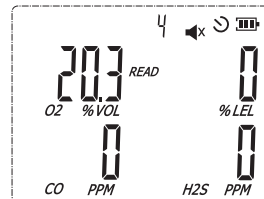

3. Others

Charging function description

When the power is insufficient or the voltage cannot be turned on due to undervoltage, please charge in time and charge it. During the charging process, the alarm light will flash and the meter will no longer detect the gas concentration and display the number of battery packs dynamically. When the number of battery packs is full and no longer changes dynamically, charging is completed. Then you can unplug the charger. Reactivate the unit, the meter can be used normally.

Warnings and Precautions

Improper operation or environment may cause accidents.

1. The instrument is strictly prohibited from collision, falling from high places or violent vibration.
2. If there is gas of high concentration, the instrument may not work properly.
3. Please operate and use strictly in accordance with the instructions, otherwise it may result in inaccurate test results or damage to the instrument.
4. Do not store the instrument in the following environments:
 - a. Places that may have water or heavy dust.
 - b. The instrument must not be stored and used in environments that contain corrosive gases (such as salt or sulfur in high concentration, etc.).
 - c. Air with other gases or chemicals.
 - d. Places of high temperature, high humidity or direct sunlight, including environments of too high and low temperatures, high humidity, electromagnetic fields, and strong sunlight.
5. Cleaning of the instrument's surface:
 - a. The window of the sensor must be kept clean. If it is dirty, the measurement will be inaccurate.
 - b. Please wipe it gently with a clean, soft cloth dampened with water (do not use alcohol, diluent, etc. to clean the case, especially for the LCD window.).
6. In order to ensure accuracy, the instrument should be calibrated regularly, and the period can not exceed one year.
7. If the instrument breaks down, please contact our professional personnel to repair it. Other people shall not change components and wiring.



Warning: prohibit charging or disassembling batteries in an explosive environment.

TIPS: This device is equipped with rechargeable battery. If you receive the product and cannot start up, please connect with the adapter for charging before use.

Special Statement:

Our company shall hold no any responsibility resulting from using output from this product as an direct or indirect evidence. This company reserves the right of changing the product design and contents of instruction if changed the separate, notice isn't given.