

Humidity/temperature measuring instrument

testo 645 - Highly precise measurements for industry

Highly accurate humidity measurement up to ± 1 %RH

Connection of 2 plug-in probes

Measurement of temperature, relative humidity and pressure dewpoint

Internal measurement store (3000 measurement values)

PC software for the analysis, archiving and documentation of the measurement values (option)

Button for Hold, min./max. values, mean value calculation

Convenient data analysis



%RH

°C

The highly accurate thermal hygrometer testo 645 has two probe inputs for the connection of an extensive range of probes:

- Channel 1: temperature Type K/J/S, NTC
- Channel 2: combi probe humidity/temperature or temperature probe Pt 100

The measuring instrument automatically displays the measurement parameters temperature, relative humidity, dewpoint, pressure dewpoint, absolute humidity, degree of humidity and enthalpy, and additionally presents the current values, the last measured values, min., max. and mean values at the press of a button.

Measurement data can be stored by measurement site in the testo 645, and analyzed on a PC, or documented using the Testo fast printer (option). The TopSafe (option) is available for tough applications. The measuring instrument, probes and accessories can be stored safely and tidily in the transport case (option).

Technical data

testo 645

testo 645, humidity/temperature measuring instrument, with battery

Part no. 0560 6450



General technical data

Operating temperature	0 to +50 °C
Storage temperature	-20 to +70 °C
Display	LCD, 4 lines
Battery type	9V block battery
Battery life	45 h
Dimensions	215 x 68 x 47 mm
Weight	255 g
Housing material	ABS

Accuracy of temperature: ± 1 digit at +22°C

Ni 10000 sensor: meas. range: ...+180 °C

Typical battery lives: 9V block (Al-Mn) 20-45h.

The hour times are reduced by a factor of 5 if a 9V rech. battery is used

Calculated humidity parameters: td, g/m³, g/kg, J/g (pressure compensated)

Mains connection and battery recharging in instrument

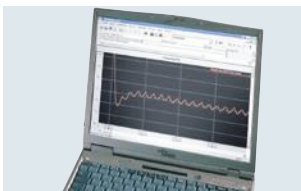

Save data by measurement site and analyze on a notebook



Connections for temperature probes Type K/J/S, NTC and combi probe humidity/temperature or temperature probe Pt100

Technical data / Accessories

Sensor type	Measuring range	Accuracy ± 1 digit	Resolution
Testo humid. sensor, cap.	0 to +100 %RH	See probe data	0.1 %RH (0 to +100 %RH)
Pt100	-200 to +800 °C	$\pm 0.1\%$ of m.v. (+200.1 to +800 °C) ± 0.2 °C (-200 to +200 °C)	0.1 °C (-200 to +800 °C)
Type K (NiCr-Ni)	-200 to +1370 °C	$\pm 0.5\%$ of m.v. (-200 to -60.1 °C) $\pm 0.5\%$ of m.v. (+60.1 to +1370 °C) ± 0.3 °C (-60 to +60 °C)	0.1 °C (-200 to +1370 °C)
Type S (Pt10Rh-Pt)	-50 to +1700 °C		
Type J (Fe-CuNi)	-40 to +750 °C	$\pm 0.5\%$ of m.v. (-200 to -60.1 °C) $\pm 0.5\%$ of m.v. (+60.1 to +1370 °C) ± 0.3 °C (-60 to +60 °C)	
NTC	-50 to +150 °C		0.1 °C (-50 to +150 °C)

Accessories	Part no.
Transport and Protection	
Transport case (plastic) for measuring instrument, probes and accessories for safe and orderly storage	0516 0445
TopSafe (indestructible protection case), with bench stand and belt clip	
Printer and Accessories	
Testo fast printer IrDA with wireless infrared interface; 1 roll thermal paper; 4 AA batteries	0554 0549
External fast charger for 1-4 AA rech. batteries, incl. 4 Ni-MH rech. batteries with individual cell charging and charge control display, incl. impulse trickle charging, integrated discharge function, with built-in international mains plug, 100-240 V, 300 mA, 50/60 Hz	0554 0610
Spare thermal paper for printer (6 rolls), permanent ink measurement data documentation legible for up to 10 years	0554 0568
Software and Accessories	
ComSoft Professional Pro software incl. data archiving	0554 1704
RS232 cable connects instrument to PC (1.8 m) for data transfer	0409 0178

Accessories

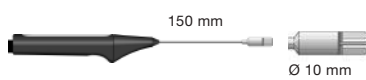
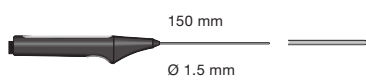
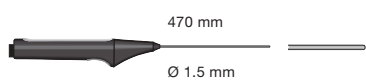
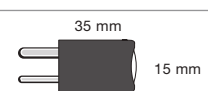

Additional accessories and spare parts	Part no.	
Desk-top power supply with international connection options	0554 1143	
9V rech. battery for instrument, instead of battery	0515 0025	
Cable, 1.5 m long, connects probe with plug-in head to meas. instrument, PUR coating material	0430 0143	
Extension cable, 5 m long, between plug-in head cable and instrument, PUR coating material	0409 0063	
Cap for bore holes, for humidity probe Ø 12 mm Measures equilibrium moisture in bore holes	0554 2140	
Control and adjustment set for Testo humidity probes, salt solution with 11.3% RH and 75.3% RH, incl. adapter for Testo humidity probes	0554 0660	
Cable, 5 m long, connects probe with plug-in head to measuring instrument, PUR coating material	0430 0145	
Adapter to connect NiCr-Ni thermocouples and probes with open wire ends	0600 1693	
Silicone heat paste (14g), Tmax = +260°C, improves heat transfer in surface probes	0554 0004	
Spare measuring tip for smelting probe	0363 1712	
testo saline solution pot for checking humidity probes, 33 %RH	0554 0636	
Calibration Certificates		
ISO calibration certificate humidity Calibration points 11.3 %RH and 75.3 %RH at +25 °C	0520 0006	
ISO calibration certificate/humidity saturated saline solutions: calibration point 11.3%RH	0520 0013	
ISO calibration certificate/humidity saturated saline solutions, calibration point 75.3%RH	0520 0083	
DAkkS calibration certificate/humidity electronic hygrometers; calibration points 11.3%RH and 75.3%RH at +25°C	0520 0206	

Probes

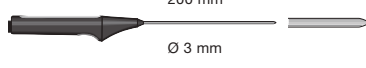

Probe type	Dimensions Probe shaft/probe shaft tip	Measuring range	Accuracy	t ₉₉	Part no.
Type K (NiCr-Ni)					
Quick-action surface probe, Plug-in head. connection cable 0430 0143 or 0430 0145 required	 150 mm Ø 10 mm	-200 to +300 °C	Class 2 ¹⁾	3 s	0604 0194
Super quick-action immersion/penetration probe for measurements in liquids, Plug-in head. connection cable 0430 0143 or 0430 0145 required	 150 mm Ø 1.5 mm	-200 to +600 °C	Class 1 ¹⁾	1 s	0604 0493
Super quick-action immersion/penetration probe for high temperatures, Plug-in head. connection cable 0430 0143 or 0430 0145 required	 470 mm Ø 1.5 mm	-200 to +1100 °C	Class 1 ¹⁾	1 s	0604 0593
Spare meas. head for pipe wrap probe, TC Type K	 35 mm 15 mm	-60 to +130 °C	Class 2 ¹⁾	5 s	0602 0092

1) According to norm EN 60751, the accuracy of Classes 1 / 2 refers to -40 to +1000/+1200 °C.

Pt100



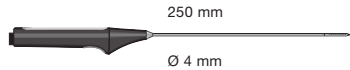

Highly accurate immersion/penetration probe, Plug-in head. connection cable 0430 0143 or 0430 0145 required	 200 mm Ø 3 mm	-100 to +350 °C	±(0.06 °C +0.1% of m.v.)	30 s	0628 0015
Flexible precision immersion probe, cable heat-proof up to +300°C, Plug-in head. connection cable 0430 0143 or 0430 0145 required	 1000 mm Ø 3.5 mm Ø 6 mm	-100 to +265 °C	±(0.06 °C +0.1% of m.v.)	80 s	0628 0016

Humidity probes



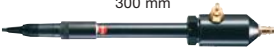

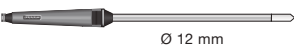
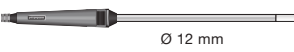

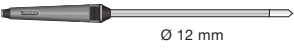
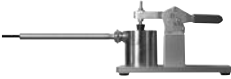
Standard ambient air probe up to +70°C, Plug-in head. connection cable 0430 0143 or 0430 0145 required	 Ø 12 mm	0 to +100 %RH -20 to +70 °C	±2 %RH (+2 to +98 %RH) ±0.4 °C (-10 to +50 °C) ±0.5 °C (remaining range)	12 s	0636 9740
Thin humidity probe incl. 4 attachable protection caps for ambient air measurements, measurements in exhaust air ducts and equilibrium moisture measurements, Plug-in head. connection cable 0430 0143 or 0430 0145 required	 250 mm Ø 4 mm	0 to +100 %RH -20 to +70 °C	±2 %RH (+2 to +98 %RH) ±0.4 °C (-10 to +50 °C) ±0.5 °C (-20 to -10.1 °C) ±0.5 °C (+50.1 to +70 °C)	15 s	0636 2130
Highly accurate reference humidity/temp. probe, Plug-in head. connection cable 0430 0143 or 0430 0145 required	 Ø 21 mm	0 to +100 %RH -20 to +70 °C	±1 %RH (+10 to +90 %RH)* ±2 %RH (remaining range) * in the temperature range from +15°C to +30°C ±0.2 °C (+10 to +40 °C) ±0.4 °C (remaining range)	12 s	0636 9741
Humidity/temperature probe, Plug-in head. connection cable 0430 0143 or 0430 0145 required	 Ø 21 mm	0... +100 %RH -20 to +70 °C	±2 %RH (+2... +98 %RH) ±0.4 °C (+0.1 to +50 °C) ±0.5 °C (-20 to 0 °C) ±0.5 °C (+50.1 to +70 °C)	12 s	0636 9742

2) According to standard EN 60751, the accuracy of Class A and B refer to -200 to +600 °C.

Probes

Probe type	Dimensions Probe shaft/probe shaft tip	Measuring range	Accuracy	t ₉₉	Part no.
Probes Process humidity					
Standard pressure dewpoint probe for measurements in compressed air systems , Plug-in head. connection cable 0430 0143 or 0430 0145 required	 300 mm	0 to +100 %RH -20 to +50 °C tpd	±0.9 °C tpd (+5 to +50 °C tpd) ±1 °C tpd (0 to +4.9 °C tpd) ±2 °C tpd (-5 to -0.1 °C tpd) ±3 °C tpd (-10 to -5.1 °C tpd) ±4 °C tpd (-20 to -10.1 °C tpd)		0636 9840
Precision pressure dewpoint probe for measurements in compressed air systems incl. cert. with test point -40°C tpd, Plug-in head. connection cable 0430 0143 or 0430 0145 required	 300 mm	0 to +100 %RH -40 to +50 °C tpd	±0.8 °C tpd (-4.9 to +50 °C tpd) ±1 °C tpd (-9.9 to -5 °C tpd) ±2 °C tpd (-19.9 to -10 °C tpd) ±3 °C tpd (-29.9 to -20 °C tpd) ±4 °C tpd (-40 to -30 °C tpd)		0636 9841
High humidity level probe w/ heated sensor element, no humidity on sensor, Plug-in head. connection cable 0430 0143 or 0430 0145 required	 300 mm Ø 12 mm	0 to +100 %RH -20 to +85 °C	±2.5 %RH (0 to +100 %RH) ±0.4 °C (-10 to +50 °C) ±0.5 °C (-20 to -10.1 °C) ±0.5 °C (+50.1 to +100 °C) * in the temperature range from +10°C to +30°C	30 s	0636 2142
Robust high temperature/humidity probe up to +180°C , Plug-in head. connection cable 0430 0143 or 0430 0145 required	 300 mm Ø 12 mm	0 to +100 %RH -20 to +180 °C	±2 %RH (+2 to +98 %RH) ±0.4 °C (+0.1 to +50 °C) ±0.5 °C (remaining range)	30 s	0628 0021
Flexible humidity probe (does not retain shape) for measurements in inaccessible places , Plug-in head. connection cable 0430 0143 or 0430 0145 required	 1500 mm 100 mm Ø 12 mm	0 to +100 %RH -20 to +180 °C	±2 %RH (+2 to +98 %RH) ±0.4 °C (+0.1 to +50 °C) ±0.5 °C (-20 to 0 °C) ±0.5 °C (+50.1 to +180 °C)	30 s	0628 0022
Probes Material and equilibrium moisture					
Robust humidity probe e.g. for measuring equilibrium moisture or for measurements in exhaust ducts to +120°C, Plug-in head. connection cable 0430 0143 or 0430 0145 required	 300 mm Ø 12 mm	0 to +100 %RH -20 to +120 °C	±2 %RH (+2 to +98 %RH) ±0.4 °C (-10 to +50 °C) ±0.5 °C (remaining range)	30 s	0636 2140
Probes aw value					
aw value set: pressure-tight precision humidity probe with certificate, measurement chamber and 5 sample bowls (plastic), Reproducibility of aw value ±0.003		0 to +1 aW 0 to +100 %RH -20 to +70 °C	±0.01 aW (+0.1 to +0.9 aW) ±0.02 aW (+0.9 to +1 aW) ±1 %RH (+10 to +90 %RH) ±2 %RH (0 to +10 %RH) ±2 %RH (+90 to +100 %RH) ±0.4 °C (-10 to +50 °C) ±0.5 °C (remaining range)		0628 0024
Measuring chamber completely					0554 9860

Covering caps

Caps for humidity probes Ø 12mm and 21mm	Illustration	For humidity probes	Part no.
Metal protection cage, Ø 12 mm for humidity probes, for measurement in flow velocities of less than 10 m/s	 Ø 12 mm	0636 9740, 0636 9715	0554 0755
Cap with wire mesh filter, Ø 12 mm	 Ø 12 mm	All humidity probes with Ø 12 mm	0554 0757
PTFE sintered filter, Ø 21 mm, for corrosive substances, high humidity range (long-term measurements), high velocities	 Ø 21 mm	All humidity probes with Ø 21 mm	0554 0666
Sintered PTFE filter, Ø 12 mm, for corrosive media, High humidity range (long-term measurements), high flow velocities.	 Ø 12 mm	0636 9769, 0636 9740, 0636 9715	0554 0756
PTFE sintered filter, Ø 12 mm, for corrosive substances, high humidity range (non-stop measurements), high flow speeds	 Ø 12 mm	0628 0021, 0628 0022, 0636 2140, 0636 2142	0554 0758
Stainless steel sintered cap, Ø 21 mm, can be screwed onto humidity probe, protection in case of high mechanical load and high velocities	 Ø 21 mm	All humidity probes Ø 21 mm	0554 0640
Stainless steel sintered filter, pore size 100 µm, probe protection in dusty atmospheres or higher flow velocities, for measurements at higher flow velocities or in contaminated air	 Ø 12 mm	0636 9740, 0636 9715	0554 0641

NDTKALA[®].CO
Non-Destructive Test (NDT) Equipment



تأمین تجهیزات و مواد مصرفی تست های غیر مخرب ایران

۰۲۱-۷۱۰۵۳۸۸۸ | ۰۹۱۲۰۲۴۶۲۷۰