

Elcometer 4270 Sag Tester

Made from stainless steel, the straight scraper has 11 notches of increasing clearance. The Elcometer 4270 Sag Tester is used to establish a coating's resistance to sag due to gravity.

A contrast chart is immediately placed in a vertical position with the thinnest film at the top.

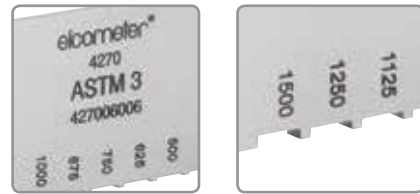
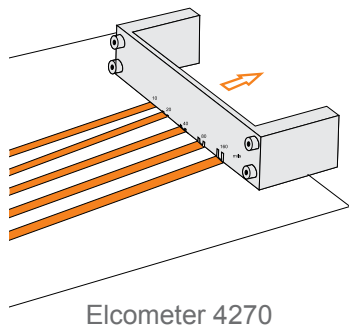

STANDARDS:
ASTM D 4400, FTMS 141 4494.1

Technical Specification C

Part Number		Description ⁺	Range		Notch Depth		Certificate
Metric	Imperial		µm	mils	µm	mils	
K0004270M001	K0US4270M001	Elcometer 4270/1	75 - 300	3 - 12	75, 75, 100, 125, 150, 175, 200, 225, 250, 275, 300	3, 3, 4, 5, 6, 7, 8, 9, 10, 11, 12	○
K0004270M002	K0US4270M002	Elcometer 4270/2	25 - 150	1 - 6	25, 37, 50, 62, 75, 87, 100, 112, 125, 137, 150	1, 1.5, 2., 2.5, 3, 3.5, 4, 4.5, 5, 5.5, 6	○
K0004270M203	K0US4270M203	Elcometer 4270/3	350 - 1500	14 - 60	350, 400, 450, 500, 620, 750, 875, 1000, 1125, 1250, 1500	14, 16, 18, 20, 25, 30, 35, 40, 45, 50, 60	○
K0004270M204	K0US4270M204	Elcometer 4270/4	100 - 600	4 - 24	100, 150, 200, 250, 300, 350, 400, 450, 500, 550, 600	4, 6, 8, 10, 12, 14, 16, 18, 20, 22, 24	○

⁺ Elcometer 4270 total width: 127mm (5")

○ Optional Calibration Certificate available.